

SLM-NVH
SealLess Magnet-drive

**High Pressure
Sealless Centrifugal Pump**

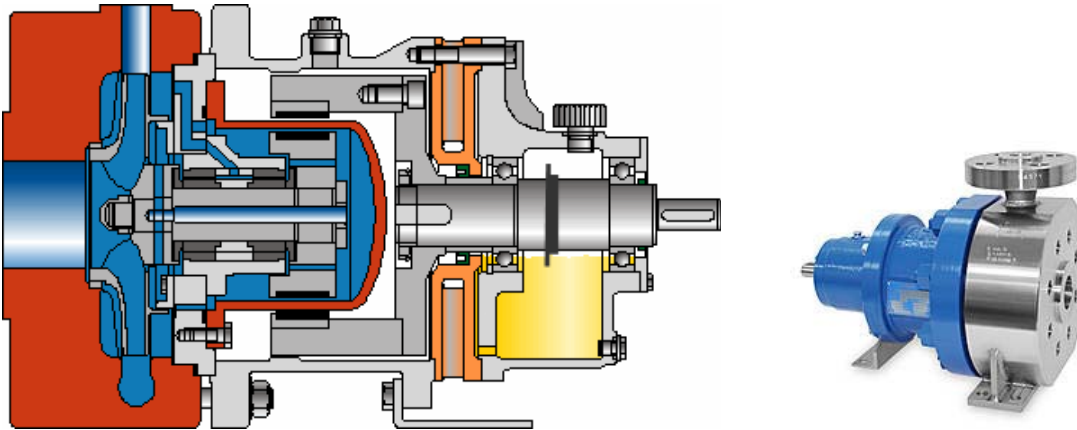

General Description

Klaus Union's SLM-NVH is a horizontal, sealless centrifugal pump with permanent magnetic coupling, for high system pressure applications. Heavy duty forged hydraulic casings and high performance isolation shells make it possible to handle system pressures up to 5,800 PSIG sealless.

Operating Parameters

- ▷ Flow rates up to 300 GPM
- ▷ Total delivery heads up to 280 feet
- ▷ System pressure up to 5,800 PSIG
- ▷ Temperature ratings from -185 °F (-120 °C) to +752 °F (+400 °C)

Pumping

- ▷ Liquid gases
- ▷ Circulating boiler water
- ▷ Aggressive, explosive and toxic liquids
- ▷ Acids & lyes
- ▷ Hydrocarbons
- ▷ Difficult-to-seal liquids
- ▷ Ultrapure liquids

Applications

- ▷ Liquid gas plants
- ▷ Power stations
- ▷ Refineries
- ▷ Chemical and petrochemical industries
- ▷ Refrigeration and heat engineering
- ▷ Galvanic engineering
- ▷ Tank installations
- ▷ Pharmaceutical industries
- ▷ Fibers industries

Construction

- ▷ Horizontal sealless centrifugal pump with enclosed impeller
- ▷ Separation of liquid chamber/atmosphere by means of an isolation shell
- ▷ Permanent magnet drive system, no mechanical seal
- ▷ Synchronous drive transmitted by inner and outer magnet systems
- ▷ Liquid lubricated internal bearings made of pure, sintered silicon carbide

Standard Materials of Construction

Pump casing:	316 SS
Impeller:	316 SS
Isolation shell:	316 SS/Hastelloy C4
Inner magnet carrier:	316 SS/Hastelloy C4
Internal bearings:	Silicon carbide, alpha grade
Intermediate lantern:	Nodular cast iron
Magnets:	Rare earth samarium cobalt

Special Alloy

Hastelloy B	Alloy 20
Hastelloy C	Titanium

Other materials available

Optional Features

- ▷ PMP 25 - Power monitor
- ▷ TPS - Isolation shell temperature probe
- ▷ Self-cleaning internal & external filter for liquids containing solids
- ▷ External flush connection
- ▷ Jacketed casing & lantern for heating/cooling
- ▷ Suction inducer for low NPSHa applications
- ▷ Isolation shell materials: Titanium
- ▷ Internal bearing materials: Carbon/SSIC, carbon/satellite

Specifications are subject to change. Materials listed are equivalent to DIN/ISO standards.

© Copyright 2009, Klaus Union, Inc., Houston, Texas