

SLM-RAV
SealLess Magnet-drive

Sealless Mixer / Agitator

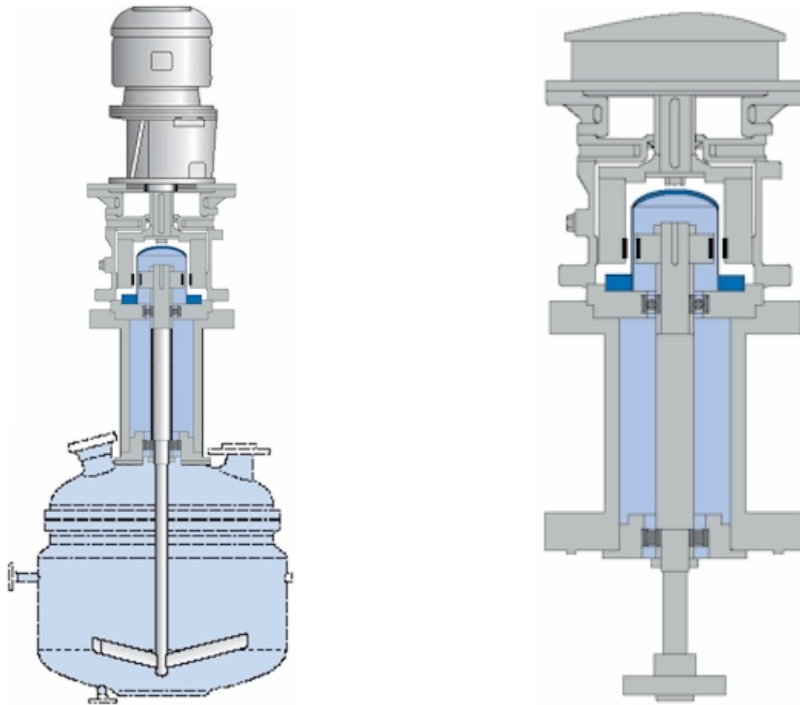

General Description

Klaus Union's SLM-RAV is a sealless magnetic mixer drive with torque capabilities of up to 3,500 ft-lbs without gear reduction. High efficiency rare-earth samarium cobalt magnets transmit torque from the motor/gearbox output shaft thru the isolation shell to the mixing shaft. The mixing shaft is supported by greased for life ball and roller bearings. To prevent tank contents from entering the bearing area a nitrogen purge is used.

Klaus Union provides both, the magnetic drive to upgrade existing mixers from sealed to sealless design, or the complete mixer including tank, blades and magnetic coupling.

Operating Parameters

- ▷ Max. transmittable torque 3,500 ft-lps
- ▷ Temperature ratings from -185 °F (-120 °C) to +752 °F (+400 °C)
- ▷ Pressure rating up to 4,640 PSIG (PN 320)

Pumping

- ▷ Acids & lyes
- ▷ Hydrocarbons
- ▷ Liquid gases
- ▷ Suspensions
- ▷ Aggressive, explosive and toxic liquids
- ▷ Difficult-to-seal liquids
- ▷ Ultrapure liquids

Applications

- ▷ Chemical and petrochemical industries
- ▷ Refineries
- ▷ Pharmaceutical industries

Construction

- ▷ Permanent magnet drive system, no mechanical seal
- ▷ Separation of liquid chamber/atmosphere by means of an isolation shell
- ▷ Synchronous drive transmitted by inner and outer magnet systems
- ▷ Sealed for life anti friction bearings support mixing shaft
- ▷ Nitrogen purge to protect anti-friction bearings

Standard Materials of Construction

Bearing lantern:	316 SS
Internal shaft:	316 SS
Isolation shell:	316 SS/Hastelloy C4
Inner magnet carrier:	316 SS/Hastelloy C4
Internal bearings:	Steel anti-friction bearings
Motor lantern:	Steel
Magnets:	Rare earth samarium cobalt

Special Alloy

Hastelloy B	Alloy 20
Hastelloy C	Titanium

Other materials available

Optional Features

- ▷ PMP 25 - Power monitor
- ▷ TPS - Isolation shell temperature probe
- ▷ CDS - Double-wall isolation shell (dual containment)
- ▷ Isolation shell materials: Titanium, non-metallic (carbon fiber/PTFE)

Specifications are subject to change. Materials listed are equivalent to DIN/ISO standards.

© Copyright 2009, Klaus Union, Inc., Houston, Texas