



Globe Valves, Bellow Sealed



Globe Valve, bellow sealed

to ANSI B16.5 and B16.10

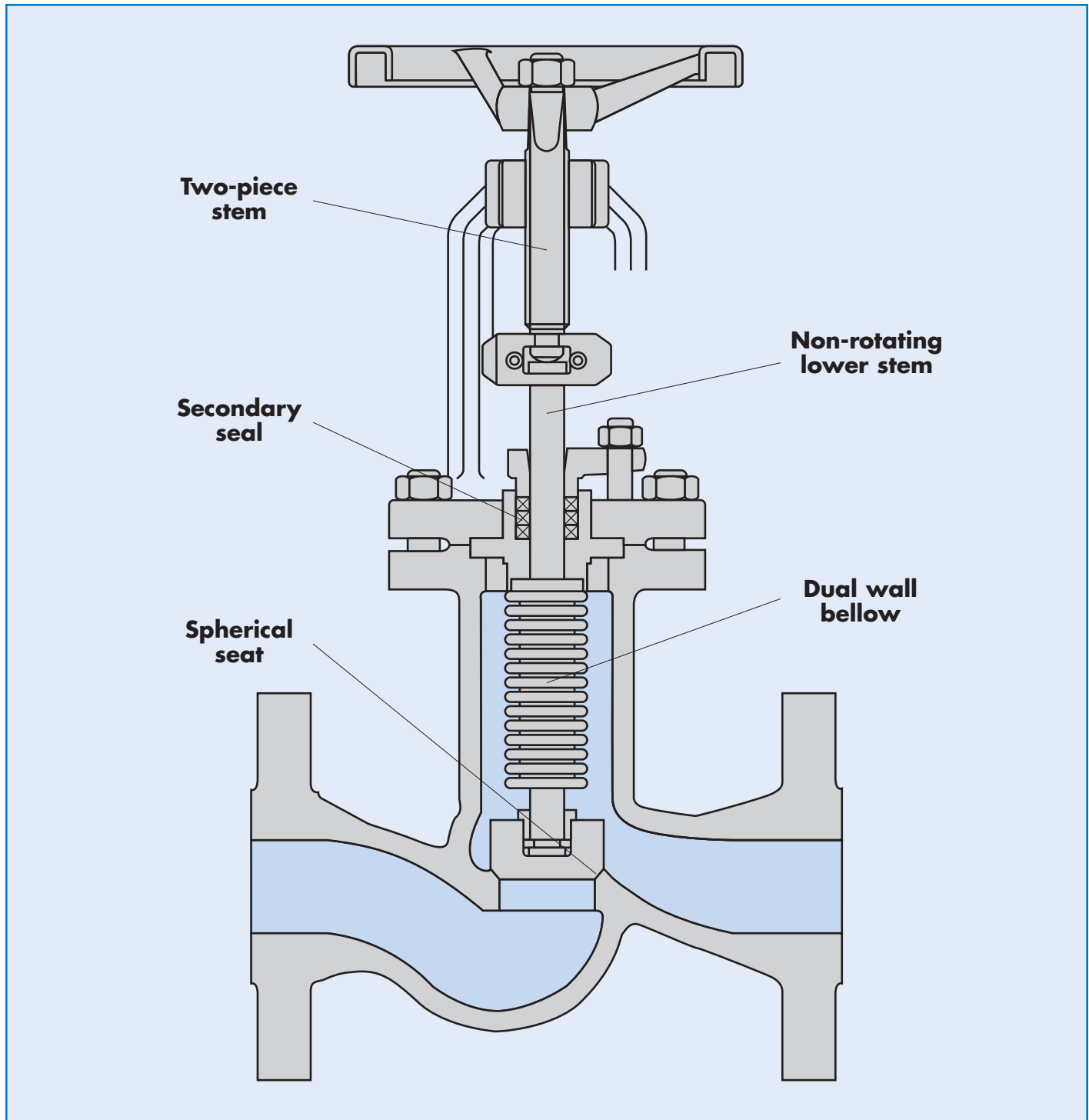

Technical Data

- ISO 9001 Certified
- "T" Pattern
- ½" – 10"
- 150# and 300#
- -20°F to 800°F
- Pressures to 740 psi

Applications

Toxic duties
Corrosive services
Flammable liquids
Volatile organic compounds

Construction

- "T" pattern
- dual wall bellow
- two-piece stem
- non-rotating lower stem
- rising stem
- rising handwheel
- secondary seal
- spherical seat

Materials

- Cast steel
- 316 SS
- Hastelloy B
- Hastelloy C
- Titanium
- Antinit
- Special alloys available

Optional Features

Heating Jacket
Stellite Seat
Throttle Plug
Conical Plug
Butt Weld
RTJ Flanges

Globe Valve, bellow sealed

to ANSI B16.5 and B16.10

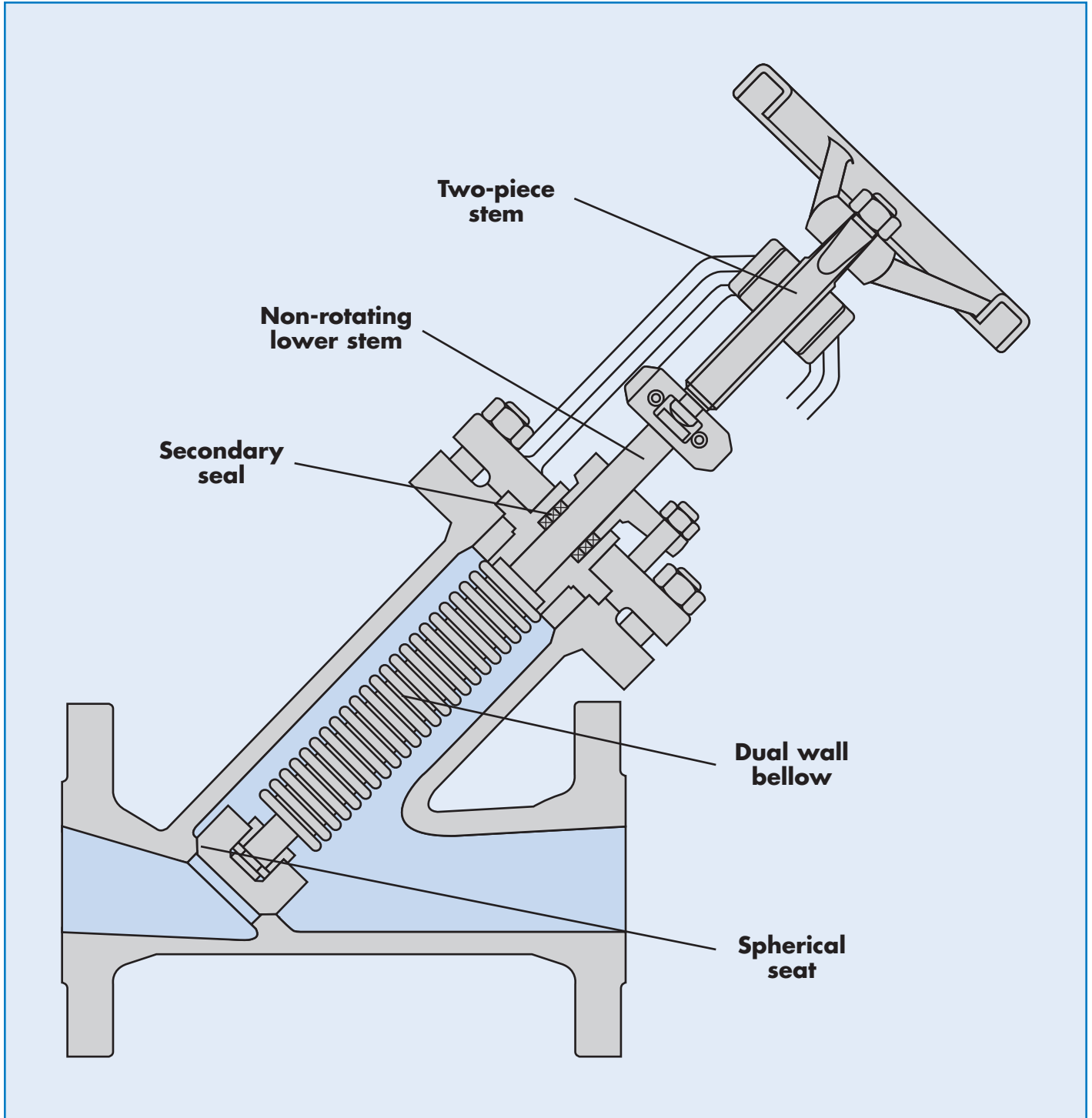

Technical Data

- ISO 9001 Certified
- "Y" Pattern
- 1/2" – 10"
- 150# and 300#
- -20°F to 800°F
- Pressures to 740 psi

Applications

Toxic duties
Corrosive services
Flammable liquids
Volatile organic compounds

Construction

- "Y" pattern
- dual wall bellow
- two-piece stem
- non-rotating lower stem
- rising stem
- rising handwheel
- secondary seal
- spherical seat

Materials

- Cast steel
- 316 SS
- Hastelloy B
- Hastelloy C
- Titanium
- Antinit
- Special alloys available

Optional Features

Heating Jacket
Stellite Seat
Throttle Plug
Conical Plug
Butt Weld
RTJ Flanges

Klaus Union, Inc.
P.O. Box 672186
Houston, Texas 77267

Phone: 281-999-1182
Fax: 281-999-1185

www.klausunion.com

